

ASME FIXED DIAPHRAGM HYDROPNEUMATIC TANKS

Job Name _____	Submitted By _____	Date _____
Location _____	Approved By _____	Date _____
_____	Order No. _____	Date _____
Engineer _____	Notes _____	
Contractor _____	_____	
Sales Rep. _____	_____	

Description

AA tanks type FXT tanks are ASME fixed diaphragm type pre-charged hydro-pneumatic tanks for commercial and industrial well and water systems, booster systems, or other potable water applications. They are designed to deliver water under pressure between pump cycles to provide sufficient flow to meet demands. The water is contained in a butyl diaphragm. All FXT tanks can be installed vertically or horizontally. Products comply with NSF/ANSI Standard 61.

Construction

Shell: Carbon Steel
 Bladder: Heavy Duty Butyl
 (NSF Listed / FDA Approved Materials)
 System Connection: Stainless Steel

Performance Limitations

Maximum Design Temperature: 240°F
 Maximum Design Pressure: 200 PSIG*
 * 250 PSIG available



Listed Material

Model Number	Part Number	Tank Volume (Gallons)	Acceptance Volume (Gallons)	Tagging Information	Quantity
FXT 400	21009999	8	5.3		
FXT 401	21010000	17	12		
FXT 402	21010005	25	17.5		
FXT 403	21010010	34	23.5		
FXT 404	21010015	78	53		
FXT 405	21010020	90	60		
FXT 415	21010025	116	93		
FXT 440	21010030	139	114		
FXT 460	21010032	166	128		
FXT 480	21010034	220	171		

Typical Specification

Furnish and install, as shown on plans, a _____ gallon _____" diameter X _____" (high) pre-charged steel hydro-pneumatic tank with a fixed heavy-duty butyl diaphragm. The tank shall be equipped with a NPT system connection and a 0.302"-32 charging valve connection (standard tire valve) to facilitate the on-site charging of the tank to meet system requirements. The tank must be constructed in accordance with most recent addendum of Section VIII Division 1 of the ASME Boiler and Pressure Vessel Code.

Each tank shall be AA tanks model number FXT- _____ or approved equal.

ASME FIXED DIAPHRAGM HYDROPNEUMATIC TANKS

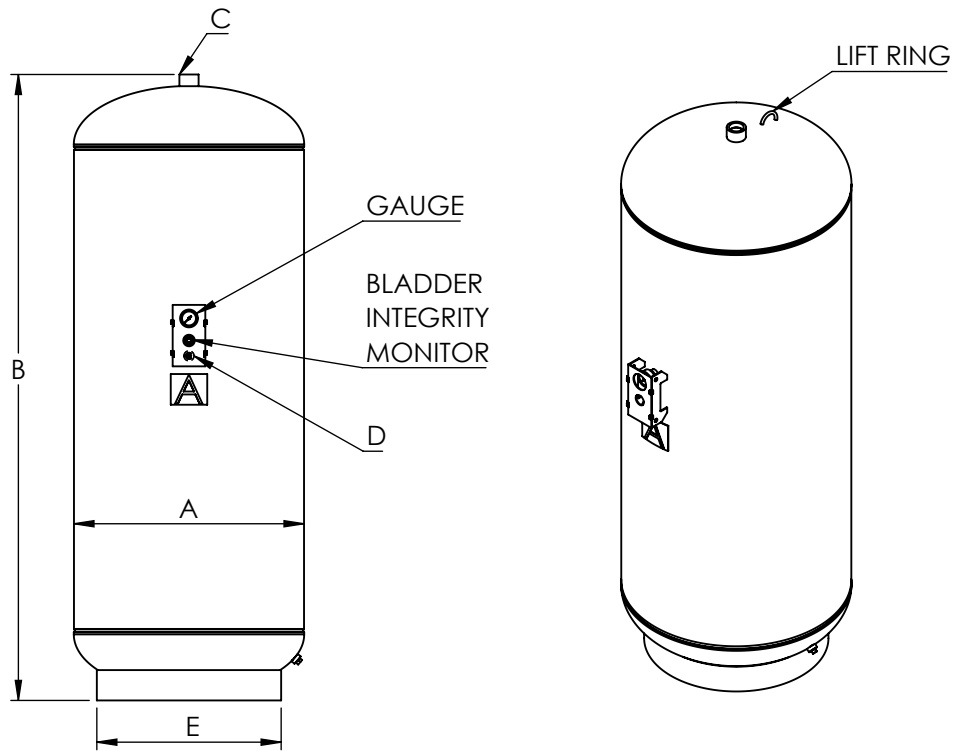

FXT-400 thru FXT-480

Dimensions & Weights

Model Number	Dimensions in Inches					Approx. Ship Wt. (lbs)
	A	B	System Connection	Charging Valve	E	
			C	D		
FXT 400	12	20	3/4	0.302-32 NC	10	34
FXT 401	16	25	1		14	64
FXT 402		33			84	
FXT 403		45			97	
FXT 404		47			259	
FXT 405	24	53	1 1/2		20	283
FXT 415		67 1/2				325
FXT 440		79 1/2				362
FXT 460		30				63
FXT 480	81 1/2		752			

Notes

- Tanks are factory pre-charged at 30 psi and field adjustable.
- Lifting rings on models FXT-402 through FXT-480.
- Available with mounting clips.
- Sight glass available.